

T-1000 Hydrogen Fuel Cell



The T-1000® hydrogen fuel cell - ultrareliable, ultraclean.

Designed specifically for communications backup power applications within the telecommunications, utility and government sectors with the only emission being water. The T-1000® uses patented Modular Cartridge Technology® for hot-swappable high reliability, ease of maintenance, and simplicity of design.

Ultra-Scalable

The T-1000® incorporates modular electronics cards which enable scalability by providing flexible configuration from 600 Watts to its full 1,200 Watt capacity.



Reli|On
+ | -[®]

A New Era in Critical Backup Power

T-1000 Hydrogen Fuel Cell

Functional Diagram

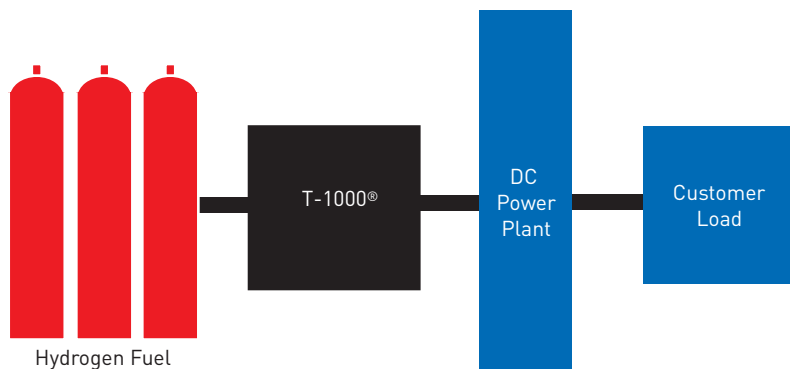

Product Specifications

		T-1000®	T-1000® in Enclosure
Physical	Dimensions (w x d x h)	14" x 21.5" x 26" 35.6cm x 54.6cm x 66cm	Modular configurations available
	Weight	98 to 164 lbs / 44 to 74 kg	
	Mounting	19" rack mount	
Performance	Rated net power	0 to 1,200 Watts	
	Rated current	0 to 50A @ 24VDC / 0 to 25A @ 48VDC	
	DC voltage	24 or 48 VDC nominal	
Fuel	Composition	Standard industrial grade hydrogen (99.95%)	
	Supply pressure to unit	3.5 to 6 psig / 24 to 41 KPag 0.24 bar to 0.41 bar	
	Consumption	7.7 slpm @ 600 Watts; 16.9 slpm @ 1200 Watts	
	Hydrogen Storage Capacity	n/a	Modular solutions scalable from 8 to 96 kWh
Operation	Ambient temperature	35°F to 115°F / 2°C to 46°C	-40°F to 115°F / -40°C to 46°C
	Relative humidity	0-95% non-condensing	
	Altitude	-197 ft to 13,800 ft / -60m to 4206m	
	Location	Indoors	Outdoors
Safety	Compliance	UL / CSA / CE	NEBS Level 3 / Seismic Zone 4
Emissions	Water	Max. 30mL / kWh	
	Noise	53 dBA @ 3.28 ft / 1 meter	
Monitoring / Control	Remote	System configuration & status / Historical and operational data	
	Communications	RJ45 / DB9 / Dry Contact	



NEBS Level 3

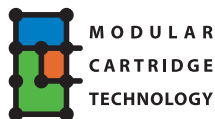

© 2008 ReliOn, Inc. All rights reserved.
Protected by U.S. Patent Nos. 6,030,718; 6,096,449;
6,218,035; 6,387,556; 6,428,918; 6,468,682; 6,773,839
and other patents pending. Product specifications
are subject to change at any time.

Contact Us

15913 E. Euclid Ave.
Spokane, WA 99216
Tel: 1-509-228-6500
Toll Free (U.S.): 1-877-474-1993
Fax: 1-509-228-6510
www.relion-inc.com

